

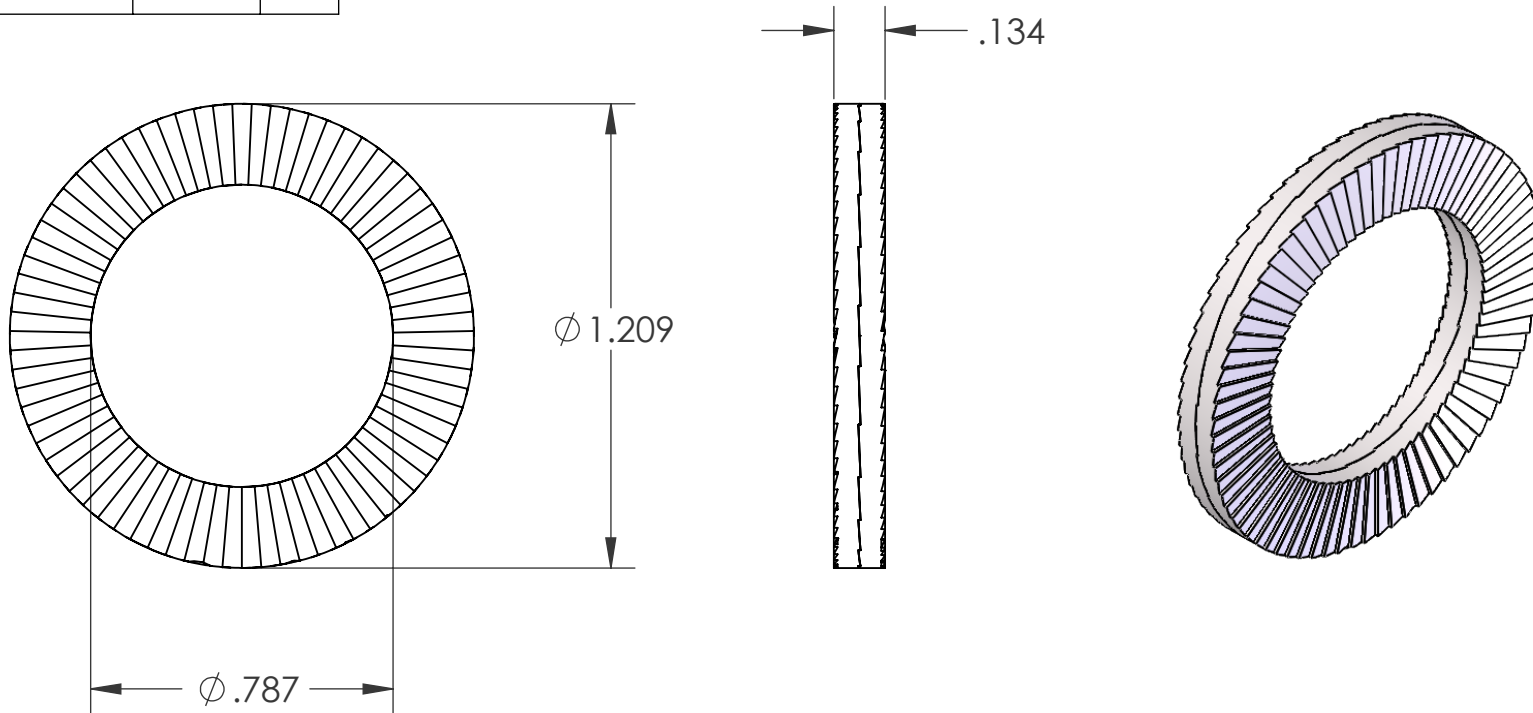

REVISIONS			
REV.	DESCRIPTION	DATE	ECN
A	INITIAL RELEASE	2/27/17	2555
B	HEAT TREAT WAS 480 - 540 HV, .134 WAS .130, 1.209 WAS 1.210, .787 WAS .790	3/30/17	2615
C	MATERIAL UPDATE	7/12/2018	3056



**PROPRIETARY AND CONFIDENTIAL**  
 THIS DRAWING, AND THE INFORMATION CONTAINED HEREIN, ARE THE PROPERTY OF SHEREX AND ARE NOT TO BE USED IN ANY MANNER DETRIMENT TO THE INTEREST OF THE COMPANY.  
 SHEREX FASTENING SOLUTIONS RESERVES THE RIGHT TO REVISE PART/DRAWING WITHOUT NOTICE.

DRAWING NO.:  
**TEC-750**

UNLESS OTHERWISE SPECIFIED:		NAME	DATE	
DIMENSIONS ARE IN INCHES TOLERANCES: ANGULAR: MACH ± 1 BEND ± 1 I.D. TOLERANCE: ± .008 O.D. TOLERANCE: ± .008 THICKNESS TOLERANCE: ± .01		DRAWN	MTB 2/27/17	
INTERPRET GEOMETRIC TOLERANCING PER: ASME Y14.5M-1994		CHECKED		
MATERIAL SCM435 OR 4130 STEEL, HT: THROUGH HARDEN 465 HV MIN		ENG APPR.	JVK 2/27/17	
FINISH DELTA PROTEKT BASE COAT (KL100) & TOP COAT (VH302GZ)		MFG APPR.		DESCRIPTION: <b>TEC WASHER GLUED PAIR 3/4"</b>
DO NOT SCALE DRAWING		Q.A.		
		COMMENTS: E-mail: <a href="mailto:info@disc-lock.com">info@disc-lock.com</a> <a href="http://www.disc-lock.com">www.disc-lock.com</a> Phone: 866-474-3739 Fax: 716-875-0358		
		SIZE	PART NO.:	REV
		<b>A</b>	<b>TEC-3/4</b>	<b>C</b>
		SCALE: 2:1	WEIGHT:	SHEET 1 OF 1